

TerTech

WIPEFIL

Manual Brush Filter

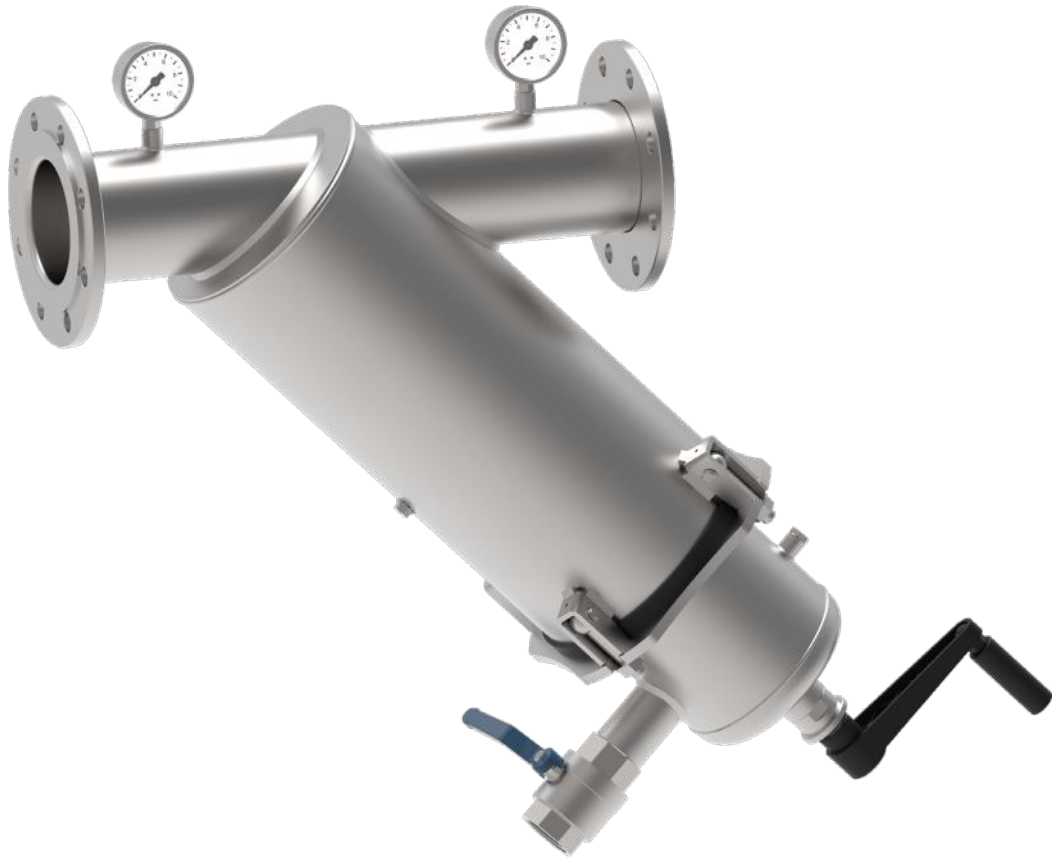

WIPEFIL

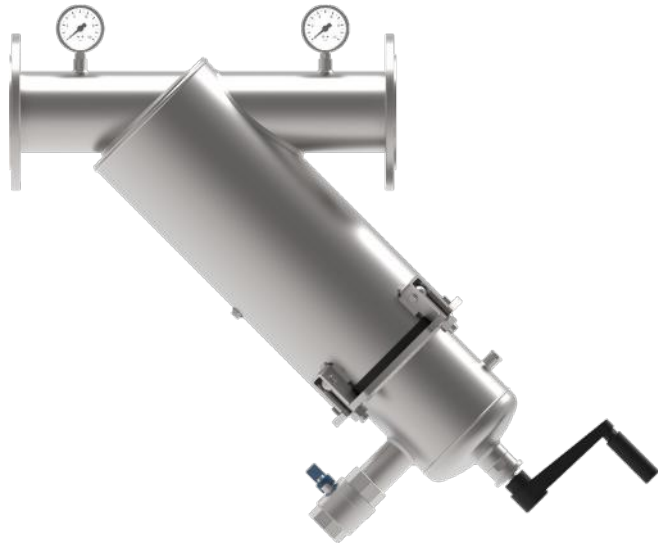

WIPEFIL is a screen filter with a manually-operated Brush cleaning system which allows the operator to easily clean the filtering screen in a matter of seconds without opening the cover. The filter's vessel and cleaning system are completely made of stainless steel supplemented with Nylon Brushes which makes the filter very robust and low-maintenance.

It is ideal to treat water loaded with non-colloidal suspended solids and is usually implemented in well-water, canals, rivers and industrial applications; it is available in 2 different constructive shapes, Y and L, in order to adapt to different installation layouts.

The wide array of filter screens, supplied with a PES or Stainless Steel AISI 316 filtering mesh, allows the user to choose between various filtration degrees, ranging from 3000µm to 80µm.

WIPEFIL is supplied complete of pressure gauges and emptying valves.

FILTRATION PROCESS

To-be-treated raw liquid enters the filter through the inlet connection (IN), suspended solids are retained inside the filtering element and purified liquid flow out of the outlet connection (OUT).

CLEANING

The continuous build-up of solids, trapped inside the filter mesh, creates a differential pressure between inlet and outlet that can be read on the filter's manometers.

Cleaning of the filtering element must be performed manually when the differential pressure between the inlet and outlet manometers exceeds the indicative value of 0,8-1 bar.

To perform the cleaning, it is sufficient to open the drain valve (DRAIN) and rotate the handle clockwise performing 5-6 full rotations; The drain valve can now be closed again. To perform deeper cleaning (if necessary), during the discharge and rotation phase, it is advised to completely or partially close the filter's outlet valve (OUT).

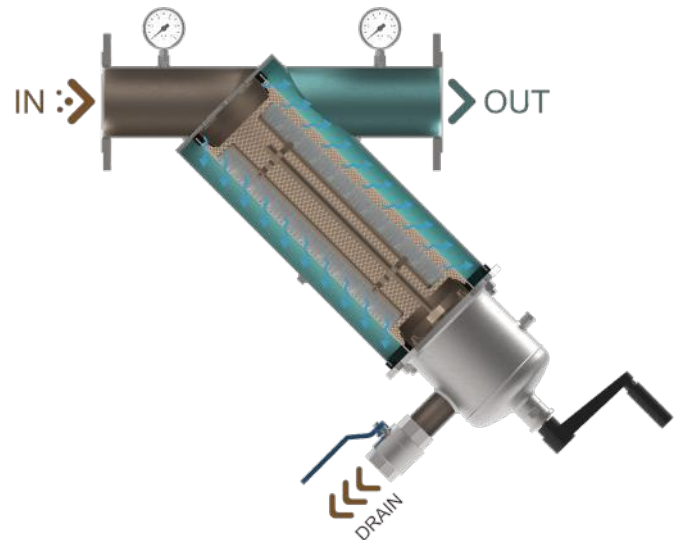

TECHNICAL SPECIFICATIONS

Design Data

Flow rate	Up to 400 m³/h
Design Pressure (bar)	PN 10
Max Temperature (°C)	80
Salinity	< 10.000 ppm
pH range	3-9
Design Code	PED 68/2014/EU

Materials

Filter Housing	Stainless Steel AISI 304 - AISI 316L
Gaskets	EPDM*
Drain	Nickel-plated Brass - AISI 316L
Pressure Gauges	Stainless Steel AISI 304 - AISI 316L
Surface finishing	Microshot Peening and Passivation

*Certified to comply to the following European Drinking Water regulations: UBA, DVGW standard W-270, WRAS and ACS

FEATURES

WIPEFIL filters are manufactured with technical and constructive features suitable for industrial applications and are available in 2 different constructive shapes. Additionally, you can choose between 2 connection types: Threaded and Flanged.

WIPEFIL's vessel is manufactured in Stainless Steel AISI 304 or in AISI 316 upon request and is available in Y and L constructive shapes. For each shape four different sizes are available: 6, 8, 18 and 30 which differ in the size of the filtering element inside them.

After the welding procedure the vessel is subjected to two surface treatments, micro-shot peening and passivation: the first provides a greater surface resistance and removes any manufacturing impurities whereas the second one reconstructs the natural passive film which constitutes the absolute stainlessness of the filter.

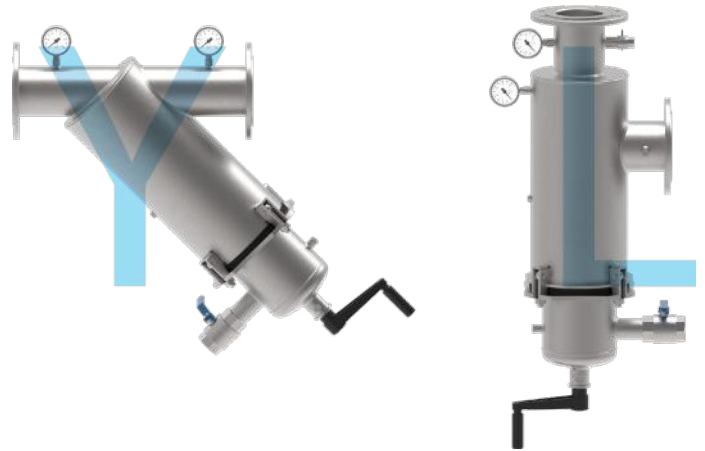

CONNECTIONS



WIPEFIL's Inlet and Outlet connections can be BSPP Threaded up to 3" and are ISO PN16 lap-joint flanged from DN80 onwards.

FILTERING ELEMENTS

PES FILTERKIT

Composed of an AISI 316 Stainless Steel cylinder within which a polyester (PES) filter tissue is inserted, its wide array of available filtering tissues and allows the customer to choose from various filtration degrees starting from 80 μm up to 810 μm .

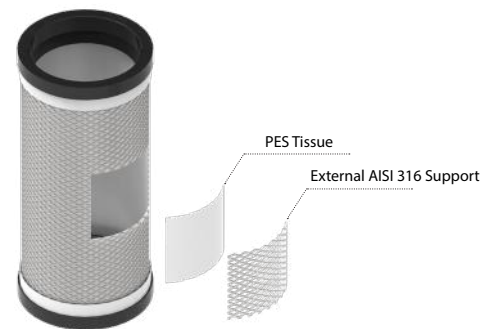

2LAY INOX FILTERKIT

Composed of a double layer stainless steel AISI 316 mesh, this type of filtering element is very resistant and proves to be an extremely valid alternative to PES FILTERKIT when it comes to harsh exercise conditions, especially when sharp or cutting suspended solids might be present inside the liquid.

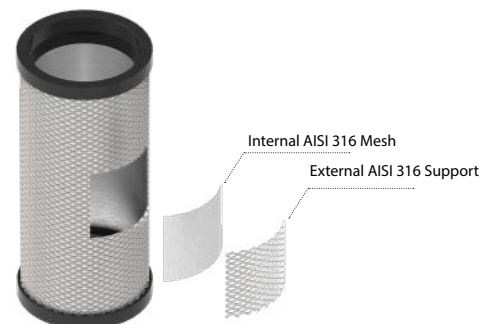

MODEL COMPOSITION

The model that identifies the filter is composed as follows:

WPFIL Filter acronym	2" Connections	Y Vessel Shape	6 Size
----------------------------	-------------------	-------------------	-----------

FLOW RATE & SIZE

You can select the product you need by identifying the IN/OUT connections and MAX flowrate first, then choosing one of the available constructive shapes and finally the relative size of the filtering element.

IN/OUT Ø	MAX FLOW RATE*		SHAPE		FILTERING SURFACE		
	[m³/h]	[l/min]	Y	L	SIZE	[cm²]	[in²]
2" BSPP	30	500	✓	✓	6	1500	233
3" BSPP	60	1000	✓	✓			
DN 80	60	1000	✓	✓			
DN100	100	1666	✓	✓			
3" BSPP	70	1166	✓	✓	8	2200	341
DN 80	70	1166	✓	✓			
DN100	110	1833	✓	✓			
DN100	120	2000	✓	✓	18	3300	512
DN150	240	4000	✓	✓			
DN100	120	2000	✓	✓	30	5400	837
DN150	260	4333	✓	✓			
DN200	400	6666	-	✓			

*Max flow rates are calculated based on clean water with a filtration degree of 120µm

With the same IN/OUT connection and the same MAX flowrate, the larger filter will require less cleaning than the smaller one.

CLEANING CYCLE

	SIZE 6	SIZE 8	SIZE 18	SIZE 30
Min. cleaning flowrate	10m³/h	15m³/h	15m³/h	20m³/h
Min. pressure during the cleaning cycle	1.5 bar	1.5 bar	1.5 bar	1.5 bar
Water consumption full cleaning cycle	55lt	84lt	84lt	110lt
Cleaning cycle's length	20-25sec	20-25sec	20-25sec	20-25sec

*For inferior flowrates and/or pressures please contact WONDERFIL Srl for more information

DIMENSIONS

Y SHAPE

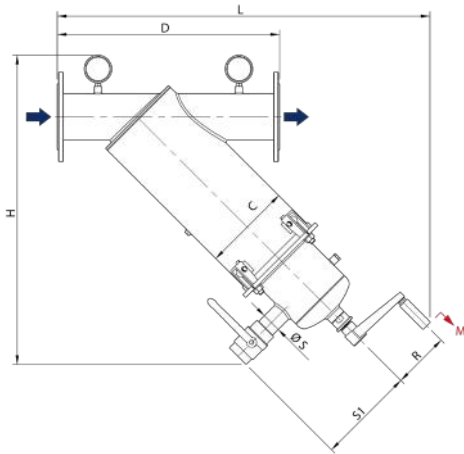

MODEL	D [mm]	L [mm]	H [mm]	C [mm]	S1 [mm]	S2 [mm]	Ø S [mm]	R [mm]	M min [mm]	WEIGHT [Kg]
WPF1 2" Y 6	412	740	600	219	240	-	1" BSPP	140	500	21
WPF1 3" Y 6	464	765	615	219	240	-	1" BSPP	140	500	22
WPF1 80 Y 6	487	765	615	219	240	-	1" BSPP	140	500	26
WPF1 100 Y 6	547	807	627	219	240	-	1" BSPP	140	500	28
WPF1 3" Y 8	464	875	748	219	240	-	1½" BSPP	140	700	26
WPF1 80 Y 8	487	874	748	219	240	-	1½" BSPP	140	700	30
WPF1 100 Y 8	547	916	761	219	240	-	1½" BSPP	140	700	32
WPF1 100 Y 18	585	955	761	273	240	-	1½" BSPP	180	700	39
WPF1 150 Y 18	660	978	788	273	240	-	1½" BSPP	180	700	44
WPF1 100 Y 30	585	1171	978	273	255	-	2" BSPP	180	1000	47
WPF1 150 Y 30	660	1194	1006	273	255	-	2" BSPP	180	1000	52

*M = Minimum free space required for maintenance

MODEL	D1 [mm]	D2 [mm]	L [mm]	H [mm]	C [mm]	S1 [mm]	S2 [mm]	Ø S [mm]	R [mm]	M min [mm]	WEIGHT [Kg]
WPF1 2" L 6	190	310	854	390	219	240	268	1" BSPP	140	500	21
WPF1 3" L 6	190	310	854	390	219	240	268	1" BSPP	140	500	22
WPF1 80 L 6	210	310	854	410	219	240	268	1" BSPP	140	500	27
WPF1 100 L 6	210	310	854	410	219	240	268	1" BSPP	140	500	28
WPF1 3" L 8	190	310	1008	390	219	240	422	1½" BSPP	140	700	26
WPF1 80 L 8	210	310	1008	410	219	240	422	1½" BSPP	140	700	31
WPF1 100 L 8	210	310	1008	410	219	240	422	1½" BSPP	140	700	32
WPF1 100 L 18	246	350	1062	480	273	240	422	1½" BSPP	180	700	39
WPF1 150 L 18	246	350	1062	480	273	240	422	1½" BSPP	180	700	44
WPF1 100 L 30	246	350	1368	480	273	255	728	2" BSPP	180	1000	47
WPF1 150 L 30	246	350	1368	480	273	255	728	2" BSPP	180	1000	52
WPF1 200 L 30	266	350	1368	500	273	255	728	2" BSPP	180	1000	57

L SHAPE

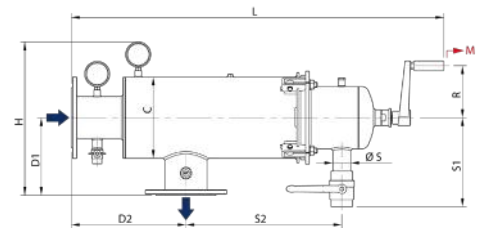

*M = Minimum free space required for maintenance

HEAD LOSS

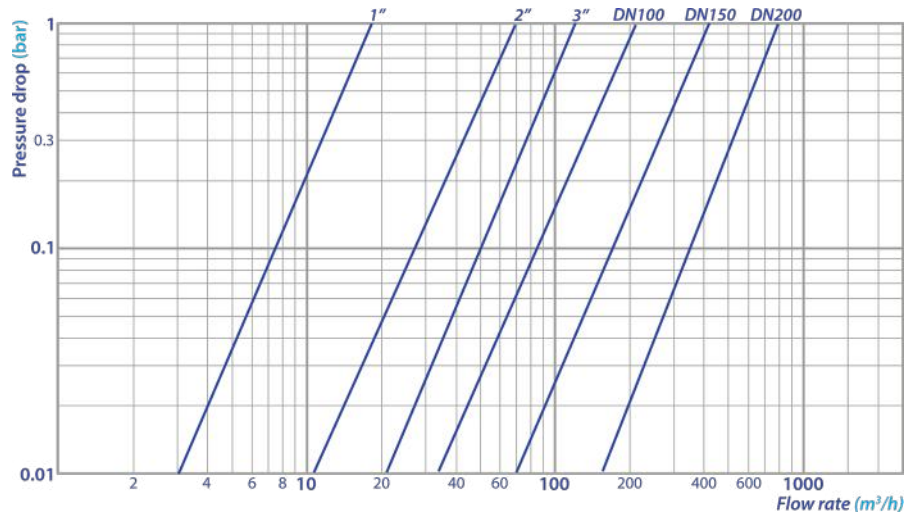

Head losses are referred to filters with 120 µm clean filtering mesh.

ACCESSORIES



DIFFERENTIAL
PRESSURE KIT

WIPEFIL can be equipped with a differential pressure control kit which detects the pressure difference between the filter's inlet and outlet connections. This greatly facilitates maintenance operations by measuring the degree of clogging of the filtering element and helps the operator plan its replacement.